

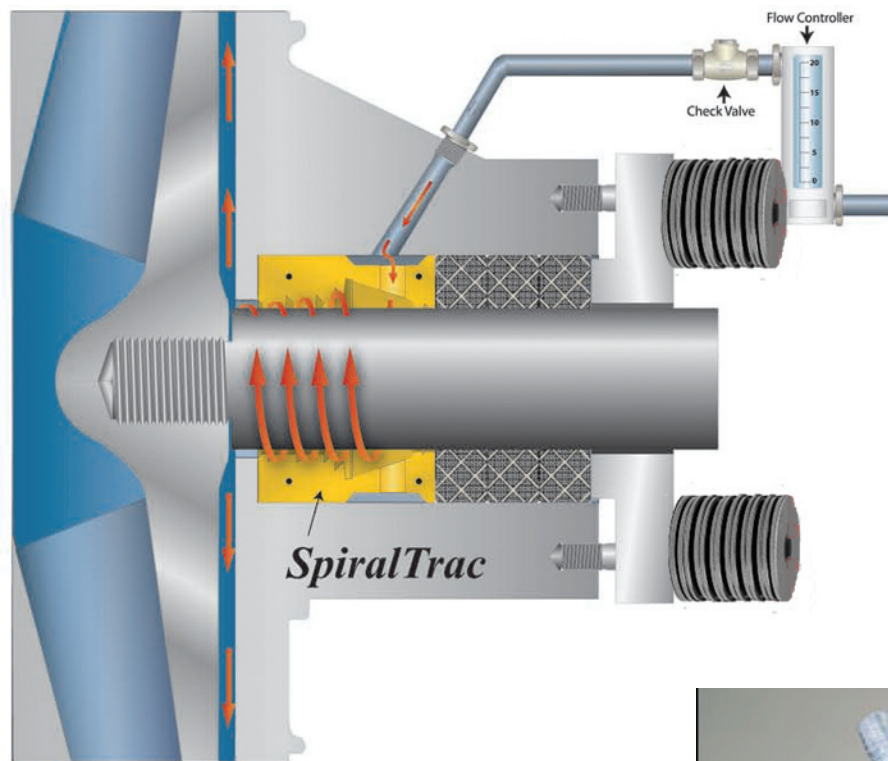

Mechanical Packing Systems

Although one of the oldest types of sealing devices known to man, technology continues to evolve in the world of mechanical packing. DuBric's "Equipment Reliability Specialists" work with customers to understand the key application parameters of their process and equipment before offering recommendations on a total engineered sealing system that will provide the most effective overall cost of operation and ownership. We can lower your operating cost by improving equipment Mean Time Between Failure. Reduce your maintenance labor, leakage, flushwater usage, and shaft/sleeve wear with an engineered mechanical packing system.



- Thousands of different materials, sizes, and configurations available
- Carbon/graphite, Teflon, FDA compliant, and other proprietary materials
- Integrate "Live Load" technology to reduce labor and improve performance
- Enviroseal's "Spiraltrac" bushing provides an optimum environment for your packing system or mechanical seal

